

Diamond

TUB & SHOWERS

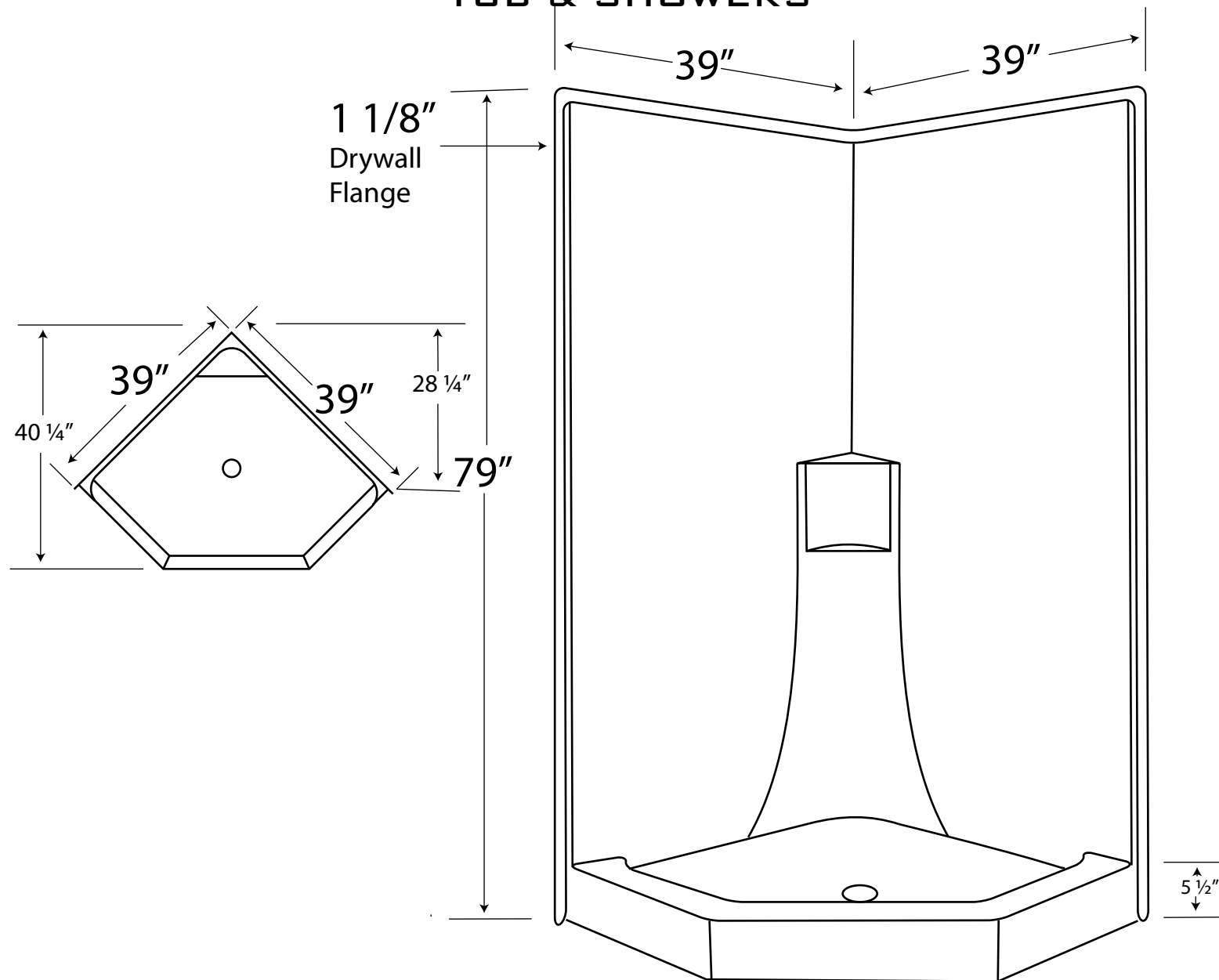

Information

Door Size:

18 1/2" x 24" x 18 1/2" w x 72" CL

Drain:

3 1/2" I.D. drain hole

Tolerances:

+0, -1/4"

Certified to conform to HUD/UM73b, ANSI Z124.1, and ASTM E-162 Flame Spread Rating 200 or less and is under a program of factory inspection.

Neo Angle Shower Model SNA 3979

Manufactured by
Front Line Mfg., Inc.
Leesburg, IN

