

# Diamond

TUB & SHOWERS

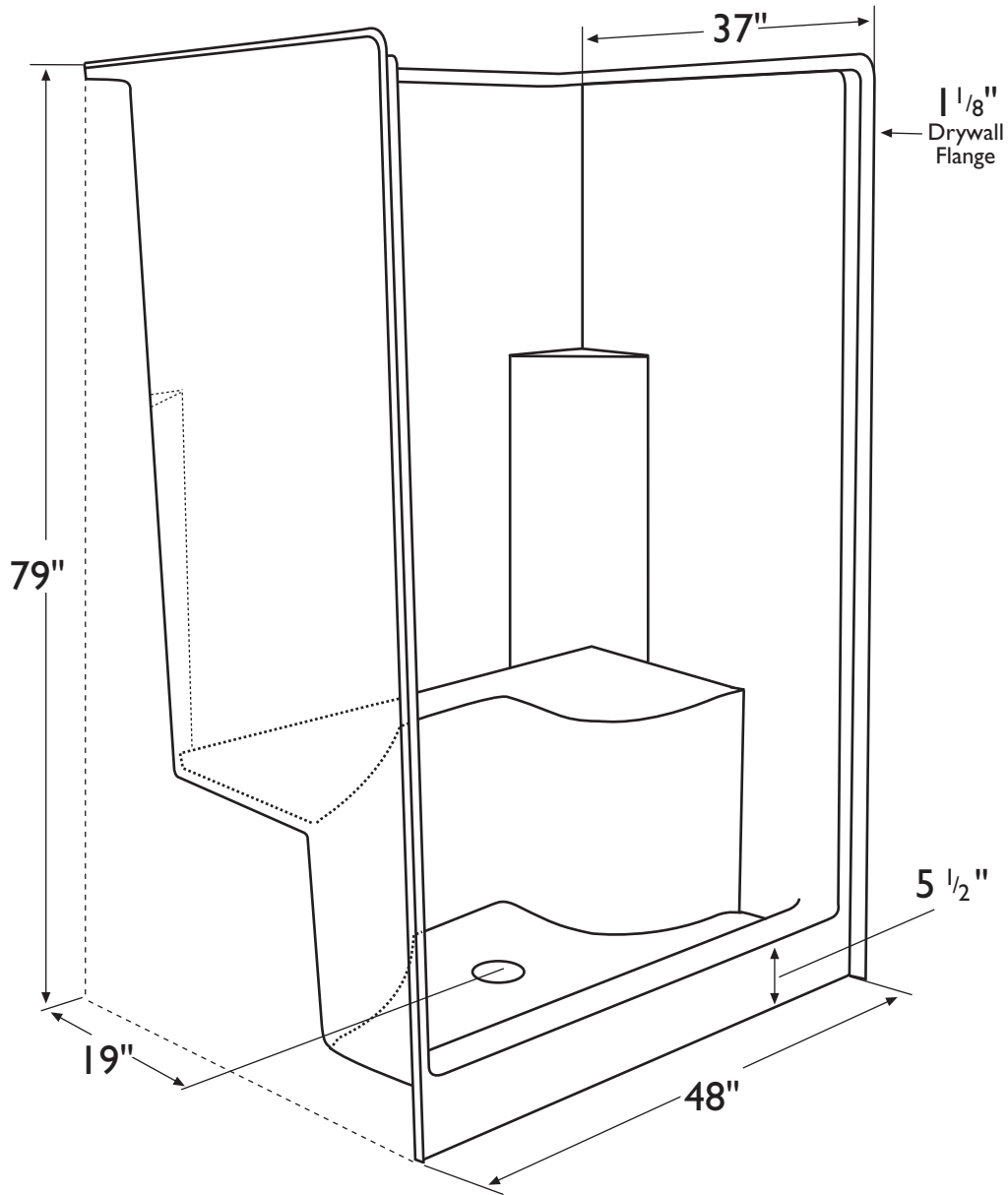

## Information

### Door Size:

44" w x 72" h

### Drain:

24" C/L from left and right side wall

19" from back wall to C/L of drain

3-1/2" I.D. drain hole

### Tolerances:

+0, -1/4"

Certified to conform to HUD/UM73b, ANSI Z124.1, and ASTM E-162 Flame Spread Rating 200 or less and is under a program of factory inspection.

## Shower Double Seat — One Piece Model SDS 483779

Manufactured by  
Front Line Mfg., Inc.  
Leesburg, IN

